

# RUNNING LED

The LEDs turns on/off one by one giving a running appearance. This running LED circuit is used for decoration purpose or as an indicator. It is a simple made of Astable Multivibrator and IC4017.

## CIRCUIT DAIGRAM:

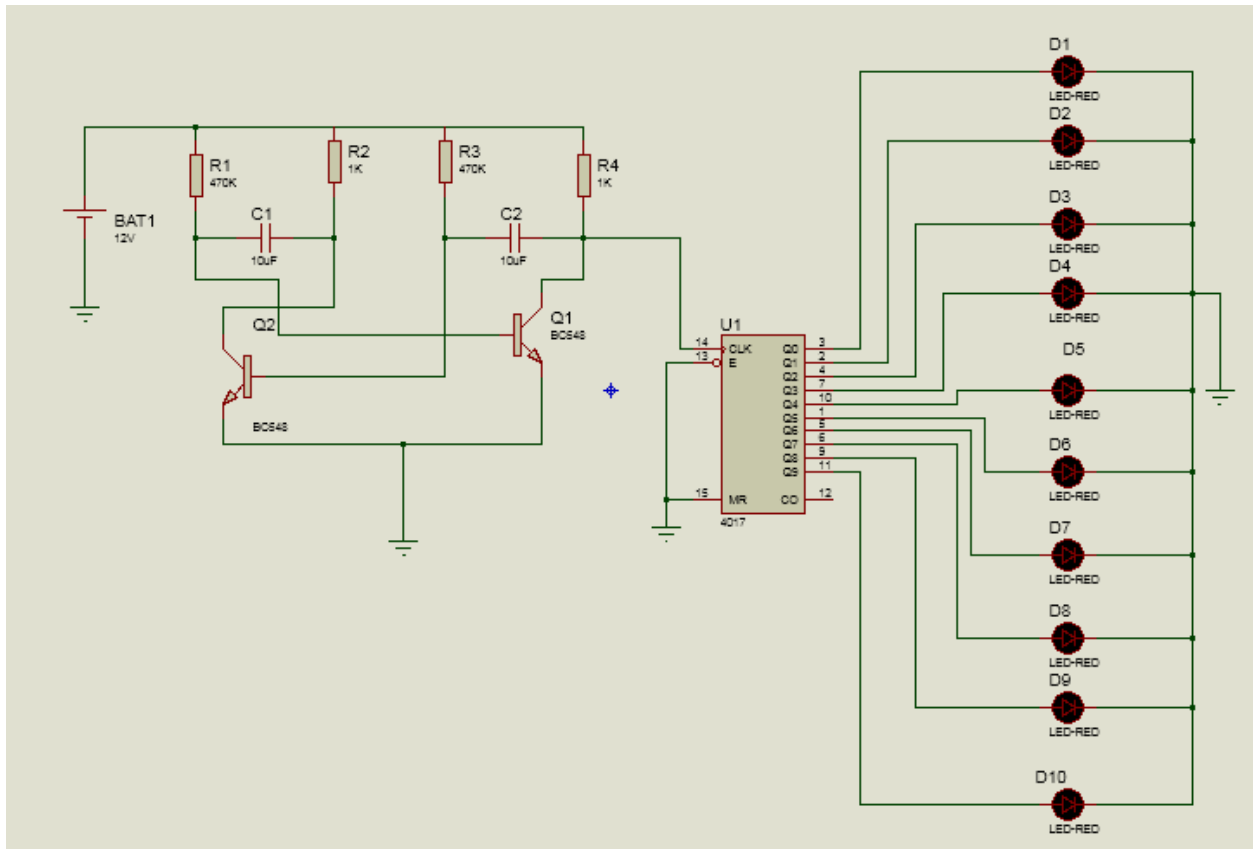

## WORKING:

When we power the circuit, LEDs start glowing one by one in circular pattern. The main part of this circuit diagram is Astable Multivibrator. An IC4017 is also connected with this circuit for lighting LEDs. Now we can connect LEDs to the 10 output pins of the IC in a circular pattern. It can produce output at the 10 pins sequentially, i.e. it produces output one by one at the 10 output pins. This output is produced through the clock pulse at PIN 14 and that clock pulse is generated by Astable Multivibrator... First clock pulse makes first output PIN (PIN 3) HIGH, second clock pulse makes first PIN LOW and second PIN (PIN 2) HIGH, third clock pulse makes third PIN HIGH, and so on. So it creates sequential ON and OFF of all the 10 OUTPUT PINS which is needed in our circuit.

## CIRCUIT COMPONENTS:

- BC548 (NPN TRANSISTOR Q1 AND Q2)



- IC4017



- LEDs (LIGHT EMITTING DIODE D1 TO D6)



- CAPACITORS (C1=C2=10uf)



- RESISTORS (R1=R3=47K , R2=R4=1K)



- BATTERY 9V



# PCB LAYOUT:

## FRONT SIDE:

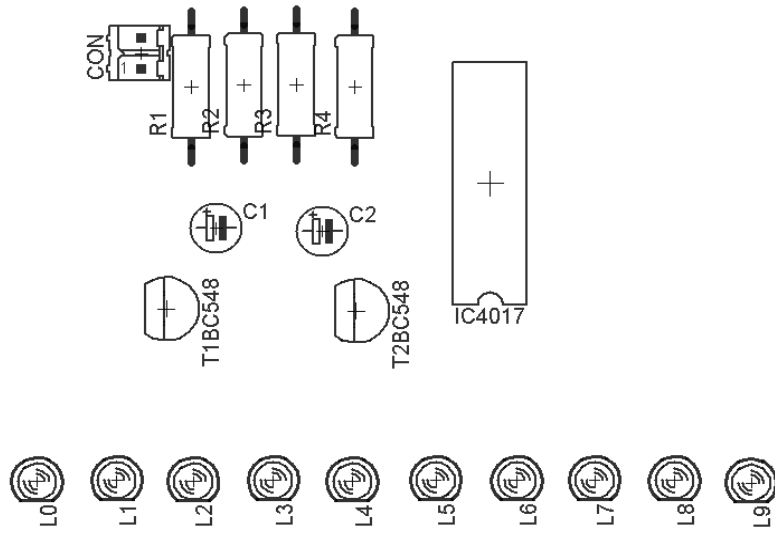

## BACK SIDE:

